



## Safety Instructions (please forward to vessel or plant crew)

In addition to the safety instructions of the Turbocharger Instruction Manual and as long as an upgrade kit is not yet installed, organizational as well as technical safety measures may reduce the likelihood of a turbocharger damage as well as the risk of a consequential personal injury. The following text, which replaces the previous versions, will provide recommendations with the goals

- to avoid any rotor failure that might possibly lead to a loss of containment and subsequent fragment discharge and
- to reduce the presence of personnel in the vicinity of the turbocharger who may be exposed to the risk of personal injury if a turbocharger damage with a subsequent containment failure occurs.

### 1) Organizational safety instructions

Make sure that only qualified personnel who have received instructions on the recommendations listed below enter the engine room.

You can significantly reduce the risk of bodily injury by following the measures listed below:

- a) Do not unnecessarily dwell in the vicinity of a turbocharger while it is in operation. MAN has defined a possible hazardous area (see below) which should be avoided while the turbocharger is in operation, unless required for the safe operation of the vessel/plant.
- b) Wear appropriate protective clothing as recommended in the Instruction Manual of your turbocharger.

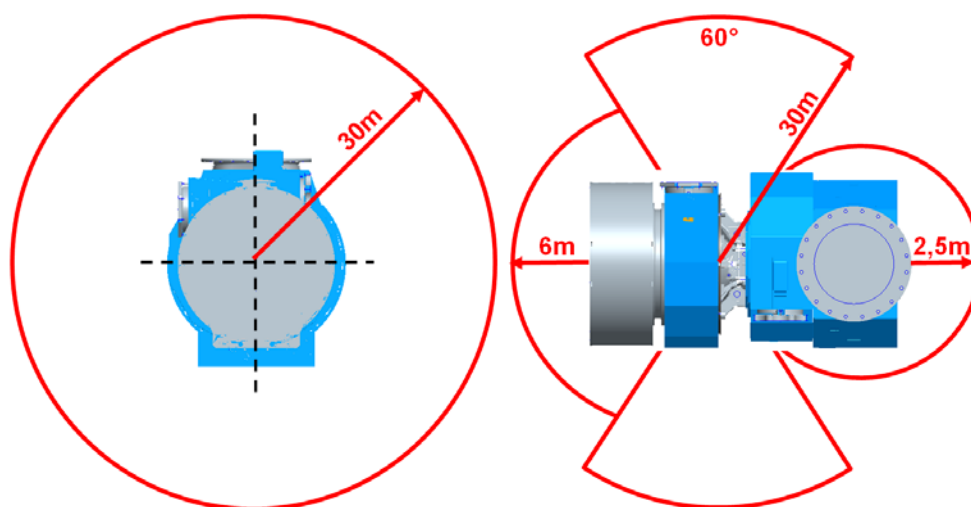

Fig. 1: Red zone = hazardous area (extended compared to the area in the Instruction Manual). We are aware that in most cases the space available around the turbocharger(s) is less than the given 30 m. However it indicates the area where the highest risk is assumed.

Optimize your path through the engine room in order to minimize your stay in the hazardous area.  
 (Please note that in the context of the illustration also the green path can only be seen as the lower risk path)

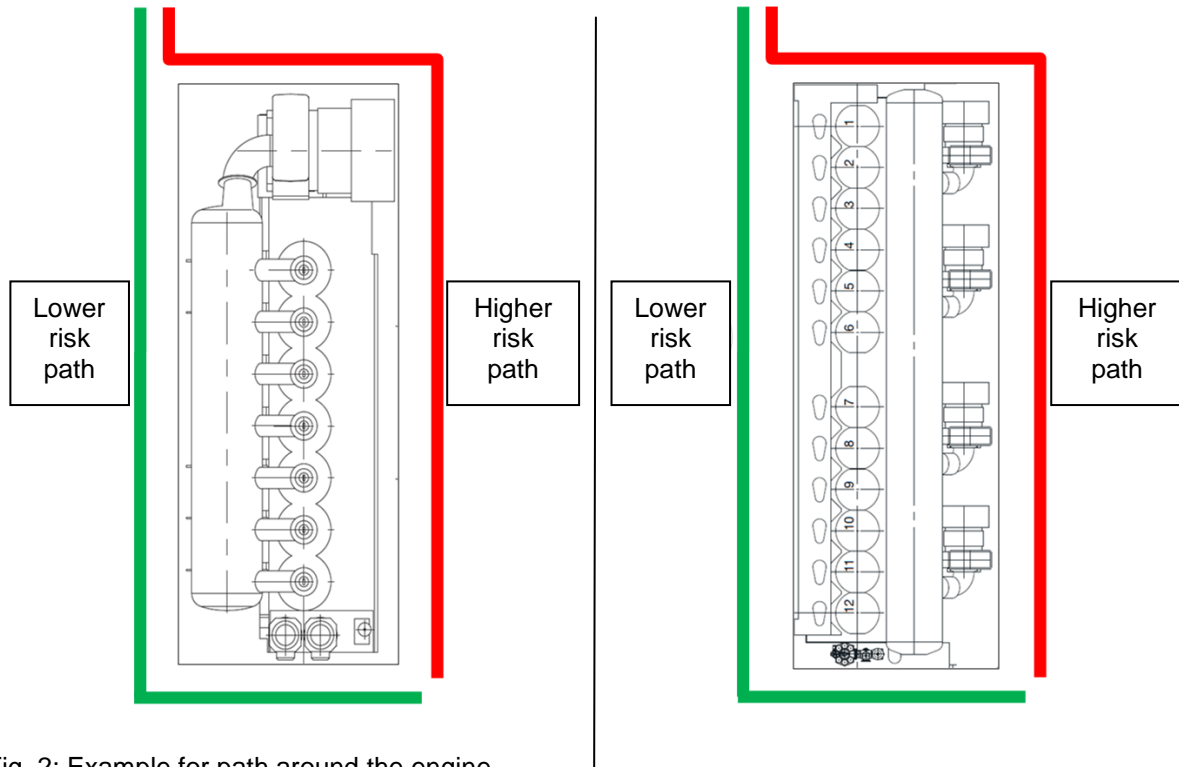

Fig. 2: Example for path around the engine

## 2) Technical safety instructions

The risk of a rotor damage in general and a compressor wheel damage in particular – as the main source of a possible containment failure – can be minimized (among others) by executing the following steps:

- a) Keep the rotor in good condition with a high focus on lubrication and cleanliness.
- b) Lack of cleanliness is one of the main reasons for an unbalance; any unbalance increases the risk of a rotor failure and a possible consequential containment failure.
- c) Actively avoid overspeed, poor fuel quality and foreign object impact, e.g. by ensuring a clean air supply.
- d) Keep the engine, e.g. exhaust valves and injection nozzles, in good condition.
- e) Perform regular maintenance work according to the instruction manual of engine and turbocharger, carried out by authorized personnel. Please find supplemental information below in chapters 3 and 4.
- f) Only employ original spare parts produced by MAN Diesel & Turbo or any of its licensees and authorized technical service partners.

**Please note:** Regardless of the turbocharger type, the risk will rise with increasing engine load and turbocharger speed.

### 3) Change of maintenance work

We recommend to change the content of the maintenance work steps as follows - please refer to the work item number in your turbocharger manual. Please make sure that the Instruction Manual you are working with corresponds with your turbocharger.

Work item	Description in the manual	Recommendation
901 / 501	Inspection for abnormal noise and vibrations	Stay out of the hazardous area (ref. Fig. 1) for this inspection. In case of an abnormal noise stay away from the turbocharger, stop the engine immediately, identify and eliminate the source of the noise before re-starting the engine.
903	Check turbocharger and system pipes for leaks	If possible, carry out this work ideally when the engine is stopped. Oil leaks as well as gas leaks can normally be identified by residues even when the engine is stopped.
905 / 508	Check all the fixing screws, casing screws and pipe connections for tight fit	Carry out this inspection only when the engine is stopped.
911 / 504	Turbine dry cleaning	Use it regularly at reduced engine load of 15% or below. Operating experience has shown that for turbochargers that are equipped with a turbine dry cleaning device only, the dry cleaning of the turbine below 15% engine load (as recommended) may not provide the desired result. In case no wet cleaning device is installed, we recommend to retrofit it for a proper cleaning effect below 15% load.
913 / 503	Turbine wet cleaning	Use it regularly at reduced engine load according to the manual.
915 / 502	Compressor wet cleaning	Stop using the cleaning device. Consider mechanical cleaning during inspections, if necessary.
917 / 505	Cleaning of air filter	Carry out this work only when engine is stopped. Make sure that the filter mat is always installed properly and undamaged. In case a U-pipe manometer is installed on your turbocharger, stop using it; it does not provide value during operation.
931	Compressor wheel inspection	Carry out visual compressor wheel inspection every 3000h (instead of an interval of 6000h).

506	Inspection of sealing air valve	Carry out this work only when the engine is stopped.
	Jet-Assist	Ensure that jet-assist pressure does not exceed 4 bar (as per operating manual).

In case you require further assistance, please contact MAN Diesel & Turbo for recommendations.

#### **4) Additional maintenance work recommended**

By carrying out the below mentioned maintenance, you substantially decrease the risk that the compressor wheel of the turbocharger can fail.

- a) The suction area of the compressor in front of the silencer and the air intake casing must be free from foreign objects at all times during the operation of the engine.
  - The intake of foreign objects into the suction area of the compressor must be prevented.
  - The operation of the turbocharger is only allowed with a correctly assembled and undamaged filter mat.
  - For all works in the area of the turbocharger, the silencer has to be covered so that foreign objects cannot get into the silencer.
  - The opening at the silencer and the opening in the compressor volute has to be covered when the silencer is disassembled.
  - The surrounding area of the turbocharger has to be cleared of foreign objects before re-commissioning after an engine stop.
  - The silencer must be protected against mechanical damage; it is not allowed to step on the silencer.
- b) Based upon field experience, the specific inspection of the compressor wheel for pre-damage as recommended in the former version of "Safety Instructions" is no longer a recommended procedure to reduce a failure risk.

**Please forward this information to affected parties and personnel!**